

These series of Stud electrodes are made from RWMA Class 2 material with TUFFALOYS' 10W (copper tungsten) on the weld face and wrench flats for easy removal from holders. The Insulator is made to withstand the constant friction that is applied as the stud is inserted and removed.

Screw Thread Size	INSULATOR		Part Number
	ID. A	Length B	
6mm 0.250 0.312, 8mm 0.375 10mm	.218	1"	175-0316-4032-10W
	.243		175-0316-40062-10W
	.256		175-0316-4042-10W
	.319		175-0316-4052-10W
	.381		175-0316-4062-10W
6mm 0.250 0.312, 8mm 0.375 10mm	.218	2"	175-0316-4031-10W
	.243		175-0316-4006-10W
	.256		175-0316-4041-10W
	.319		175-0316-4051-10W
	.381		175-0316-4061-10W
0.437 12mm 0.500	.444	1"	175-1313-4372-10W
	.479		175-1313-40122-10W
	.506		175-1313-4382-10W
	.569		175-1313-4392-10W
	.652		175-1313-4402-10W
0.437 12mm 0.500	.444	2"	175-1313-4371-10W
	.479		175-1313-4012-10W
	.506		175-1313-4381-10W
	.569		175-1313-4391-10W
	.652		175-1313-4401-10W
0.437 12mm 0.500	.694	2"	175-1313-4411-10W
	.777		175-1313-4421-10W

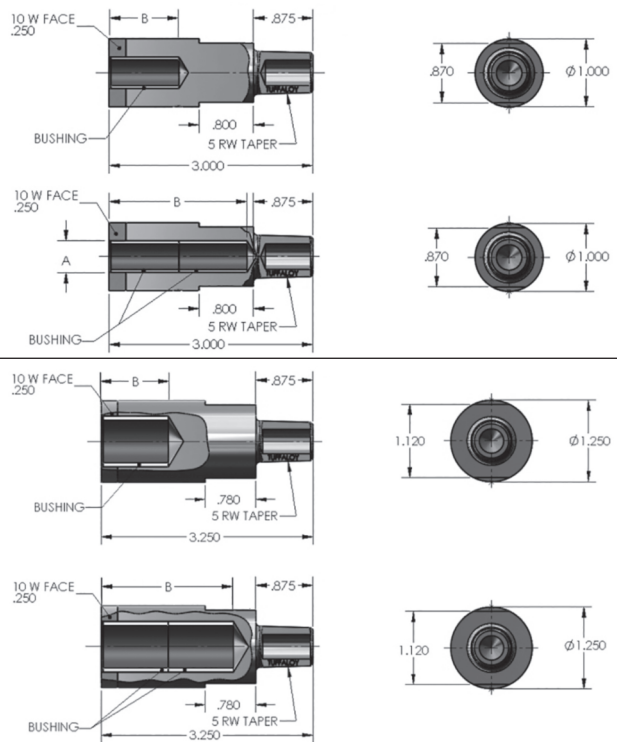

BACKUP ELECTRODES FOR UPPERS

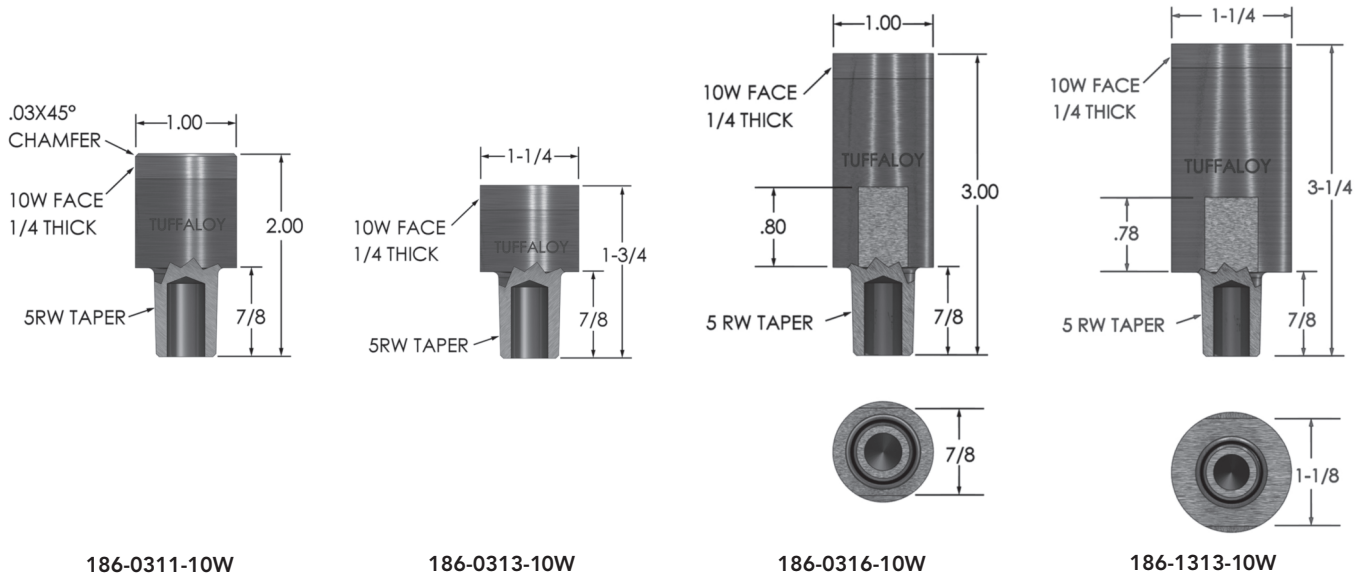

186-0311-10W

186-0313-10W

186-0316-10W

186-1313-10W

